



SEALS

EDGES, ASTRAGALS
& SPECIALTY PRODUCTS





EDGES, ASTRAGALS & SPECIALTY PRODUCTS INDEX:

Buy American.....	EA4
Door Aligning Astragals.....	EA7
Door Edges.....	EA5
Door Edges with Astragals, Active and Inactive.....	EA6
Double Egress Door Edges & Astragals.....	EA5
Finger Guard.....	EA9
Flood Shield.....	EA11-EA12
Hinge Side Finger Guard.....	EA10
LEED Green Building.....	EA4
Metal Edges & Astragals Order Form.....	EA8
Powder Coat Chart.....	EA3
Ratings and Finishes.....	EA2
"Z" Astragals.....	EA5

NUMERICAL INDEX:

FS10.....	EA11-EA12	550.....	EA6	563.....	EA7
FS22.....	EA11-EA12	551.....	EA6	570.....	EA5
FS34.....	EA11-EA12	552.....	EA6	572.....	EA5
540.....	EA5	553.....	EA6	574.....	EA5
541.....	EA5	555.....	EA5	2248.....	EA9
542.....	EA5	560.....	EA7	2252.....	EA10
543.....	EA5	561.....	EA7		
545.....	EA5	562.....	EA7		

RATINGS AND FINISHES

RATING SYMBOLS LEGEND



POSITIVE PRESSURE - CERTIFIED by UL to ANSI/UL10C; complies with IBC, NFPA 80 and NFPA 252 for application to Hollow Metal fire doors rated up to 3 Hrs., and Wood fire doors rated up to 90 minutes.



CERTIFIED by UL to CAN/ULC-S104 and ANSI/UL10B, complies with NFPA 80 and NFPA 252 for application to Hollow Metal fire doors rated up to 3 Hrs., and Wood fire doors rated up to 90 minutes.

Corrosion Resistant Sealer: A polymeric green seal (non-chrome) corrosion resistance extender is applied under all NGP powder coat finishes. Laboratory salt spray tests prove a dramatic increase in corrosion resistance on steel products with this sealer applied to the metal prior to the powder coat finish.

Salt Spray Test Results: Steel door edges and astragals with NGP's corrosion resistant sealer and powder coat finish withstood 1,248 hours without failing. This is 2 ½ times longer than the protection provided by powder coating only.

POWDER COAT CHART

STANDARD & OPTIONAL COLORS

Colors may have a slight variation on your monitor or printer.
Contact NGP for actual color samples to be mailed.

STANDARD COLORS:



GPZ-Gray Primer

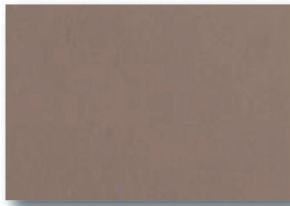

T-Tan

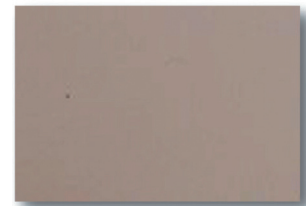

BPR-Beige Primer
(matches Steelcraft)



DKB-Dark Bronze

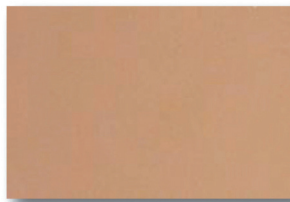

PTY-Putty
(matches Anemostat Beige)



CAB-California Bronze
(matches Anemostat)

OPTIONAL COLORS:

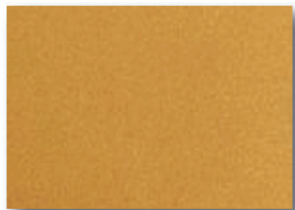

B-Brass



WB-Walnut Brown
(matches Timely Browntone)



ASL-Aluminum Silver
(metallic)

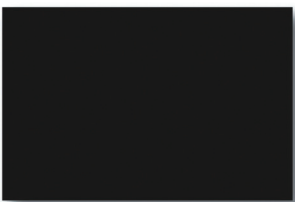

TBL-Textured Black
GBL-Gloss Black
MBL-Matte Black

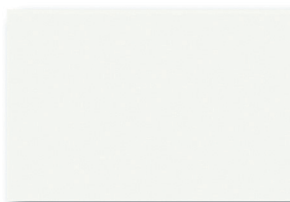

MW-Magnolia White
(matches Timely Western White)

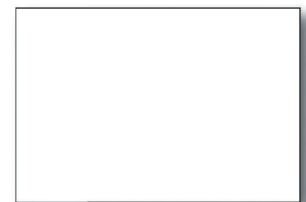

W-White

POWDER COAT FINISH

The standard finish for each product is indicated on the catalog page and in the price list and will be provided unless an optional finish is indicated. The following color options can be provided on any Door Edge & Astragal:

Custom colors and color matching available – Consult customer service for details

LEED GREEN BUILDING

LEED (Leadership in Energy and Environmental Design) Green Building Rating System® is a national standard for developing high-performance, sustainable buildings developed by the U. S. Green Building Council. This letter highlights the eligible LEED V.4 point contributions for National Guard Products.

MRC2 Building Product Disclosure and Optimization - Environmental Product Declaration (EPD)

National Guard Products is able to provide Type III Product Specific Environmental Product Declarations for its Threshold, Gasketing, Lite Kits, Louvers and Continuous Geared Hinge products. The EPDs can be found at: ngp.com/epds.

MRC3 Building Product Disclosure and Optimization - Sourcing of Raw Materials

National Guard Products is able to provide a third party reviewed corporate sustainability report that includes the environmental impacts of extraction operations and activities associated

with National Guard Products supply chain. This report was created using the Global Reporting Initiative (GRI) Sustainability Reporting framework and satisfies MRC3 Option 1. The report can be found at: ngp.com/report.

For Option 2 of the MRC3 credit, products purchased from National Guard Products are eligible to participate in the NGP Extended Producer Responsibility program, RE-NGP managed by National Guard Products.

Additionally for Option 2 of the MRC3 credit, average percentages of recycled materials utilized in and contained in NGP products may be found at: ngp.com/leed.

MRC4 Building Product Disclosure and Optimization - Material Ingredients

National Guard Products is able to provide product specific Health Product Declarations Product Specific for its Threshold, Gasketing, Lite Kits and Louver products. The HPDs can be found at: ngp.com/hpds.

BUY AMERICAN REQUIREMENTS

Buy American Act

Over 99% of our products are produced in the United States as a domestic construction material, as defined in the Buy American Act (BAA) of March 1933 and amended by the Buy American Act of 1988 and FAR 52.225-9. A Buy American Certificate may be obtained on our website ngp.com.

Buy America

More than 99% of our products comply with Buy America Requirements of 49 U.S.C. 5323(j)(1), and the applicable regulations in 49 CFR part 661. Contact us for a Certificate of Compliance for your project.

Components of unknown origin are considered to have been produced or manufactured outside the United States.

DOOR EDGES AND ASTRAGALS



NGP Order Form (Page EA8) Indicating Model Number, Hand, Net Length, Hardware Preps, and Precise Hardware Locations Must Accompany All Orders.

- 20 Ga. Cold Rolled Steel on Edges and "Z" Astragals
- 18 Ga. Cold Rolled Steel on Astragal Welded to Edges
- For 1 3/4" Thick Doors (Inside Dim. 1 3/4" Actual)
- #8 x 3/4" Flat Undercut Phillips Head SMS
- Standard Finish = Tan (T) Powder Coat

Available Options:

- Powder Coat Color Options - See Page EA4
- Stainless Steel 20 Ga., Type 304, #4 Brushed Finish - Suffix SS"
- Galvanneal
- Torx Security Screws
- Special Door Thickness: 1 3/8", 2", 2 1/4"
- Lead Lining .030" Thick

"Z" ASTRAGALS

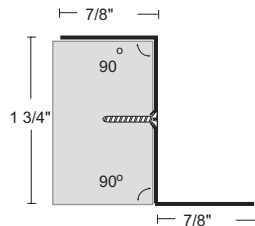

570 SQUARE EDGE

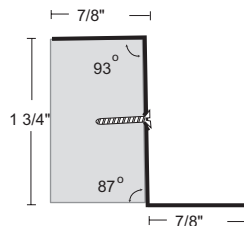

572 BEVELED EDGE ON ACTIVE LEAF

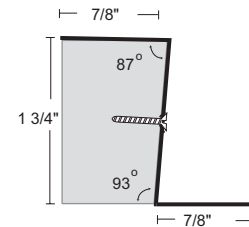

574 BEVELED EDGE ON INACTIVE LEAF

DOOR EDGES

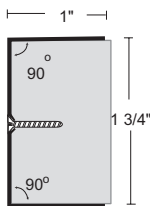

540 SINGLE SQUARE EDGE

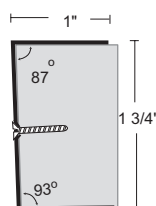

542 SINGLE BEVELED EDGE

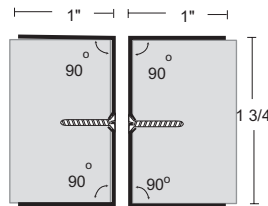

541 SQUARE EDGE SET

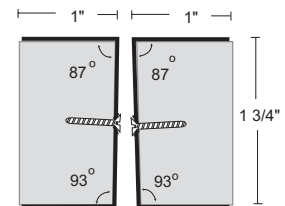

543 BEVELED EDGE SET

DOUBLE EGRESS

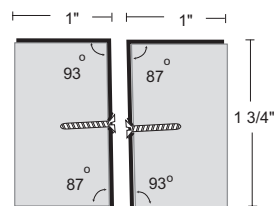

545 PARALLEL BEVEL EDGE SET FOR DOUBLE EGRESS DOORS

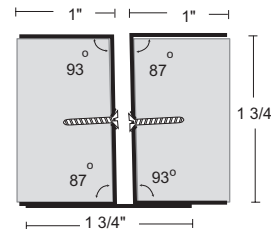

555 PARALLEL BEVEL ASTRAGAL SET FOR DOUBLE EGRESS DOORS

DOOR EDGES AND ASTRAGALS



NGP Order Form (Page EA8) Indicating Model Number, Hand, Net Length, Hardware Preps, and Precise Hardware Locations Must Accompany All Orders.

- ▶ 20 Ga. Cold Rolled Steel on Edges
- ▶ 18 Ga. Cold Rolled Steel on Astragal Welded to Edges
- ▶ For 1 3/4" Thick Doors (Inside Dim. 1 3/4" Actual)
- ▶ #8 x 3/4" Flat Undercut Phillips Head SMS
- ▶ Standard Finish = Tan (T) Powder Coat

Available Options:

- ▶ Powder Coat Color Options - See Page EA4
- ▶ Stainless Steel 20 Ga., Type 304, #4 Brushed Finish - Suffix SS"
- ▶ Galvanneal
- ▶ Torx Security Screws
- ▶ Special Door Thickness: 1 3/8", 2", 2 1/4"
- ▶ Lead Lining .030" Thick

ASTRAGAL ON ACTIVE LEAF

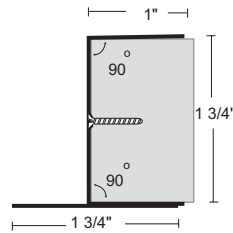

550 SINGLE ASTRAGAL SQUARE EDGE

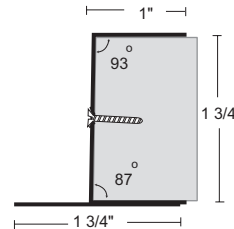

552 SINGLE ASTRAGAL BEVELED EDGE

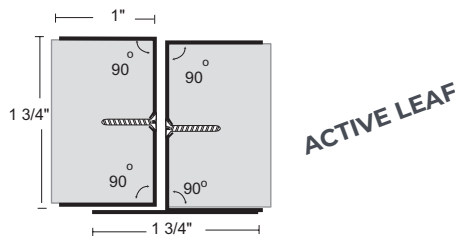

551 ASTRAGAL SET SQUARE EDGE

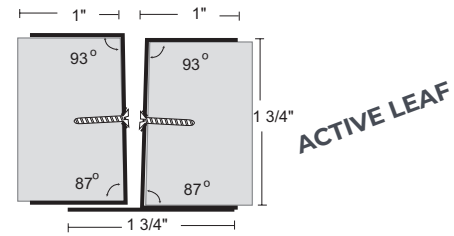

553 ASTRAGAL SET BEVELED EDGE

Astragals Mounted on Active Leaf that are Prepped for a Lockset Will Be Notched for the Strike Lip, Unless Specified Otherwise.

DOOR EDGES AND ASTRAGALS



NGP Order Form (Page EA8) Indicating Model Number, Hand, Net Length, Hardware Preps, and Precise Hardware Locations Must Accompany All Orders.

- ▶ 20 Ga. Cold Rolled Steel on Edges
- ▶ 18 Ga. Cold Rolled Steel on Astragal Welded to Edges
- ▶ For 1 3/4" Thick Doors (Inside Dim. 1 3/4" Actual)
- ▶ #8 x 3/4" Flat Undercut Phillips Head SMS
- ▶ Standard Finish = Tan (T) Powder Coat

Available Options:

- ▶ Powder Coat Color Options - See Page EA4
- ▶ Stainless Steel 20 Ga., Type 304, #4 Brushed Finish - Suffix SS"
- ▶ Galvanneal
- ▶ Torx Security Screws
- ▶ Special Door Thickness: 1 3/8", 2", 2 1/4"
- ▶ Lead Lining .030" Thick

ASTRAGAL ON INACTIVE LEAF

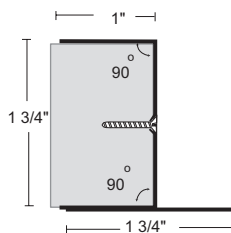

560 SINGLE ASTRAGAL SQUARE EDGE

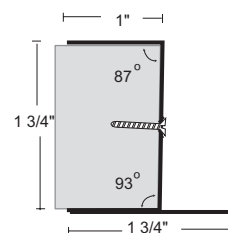

562 SINGLE ASTRAGAL BEVELED EDGE

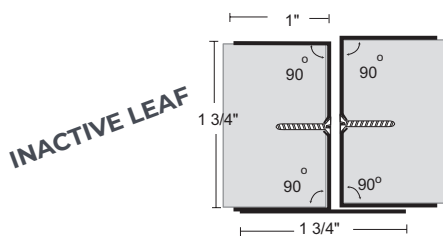

561 ASTRAGAL SET SQUARE EDGE

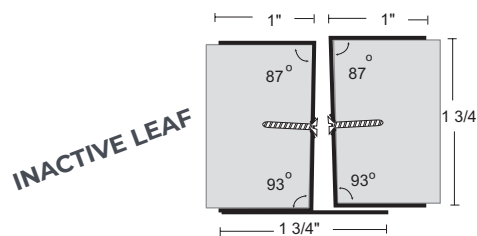

563 ASTRAGAL SET BEVELED EDGE

Astragals Mounted on Active Leaf that are Prepped for a Lockset Will Be Notched for the Strike Lip, Unless Specified Otherwise.

METAL EDGES & ASTRAGALS

ORDER FORM

STEP 1 ORDER FORM FOR METAL EDGES/ASTRAGALS

ASTRAGAL ON ACTIVE DOOR		ASTRAGAL ON INACTIVE DOOR	
MODEL #		MODEL #	
551	(OUTSWING)	561	(INSWING)
553	RHR ACTIVE	563	RH ACTIVE
550	LHR INACTIVE	560	LH ACTIVE
552	RHR INACTIVE	562	RH INACTIVE
572		574	
OTHER MODEL #		OTHER MODEL #	
	(INSWING)		(OUTSWING)
	LH ACTIVE		RHR ACTIVE
	RH INACTIVE		LHR INACTIVE

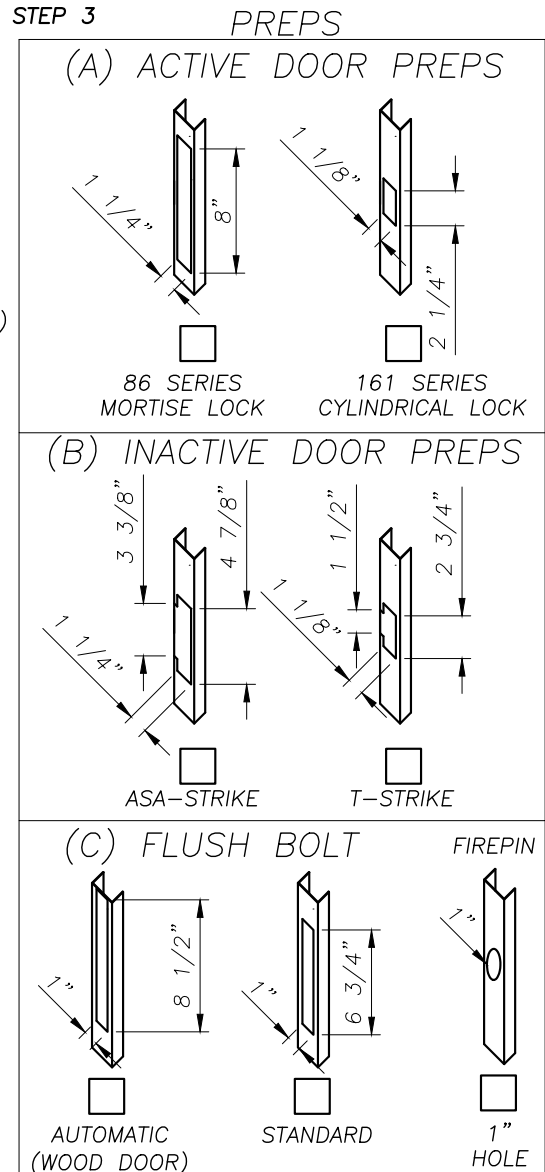
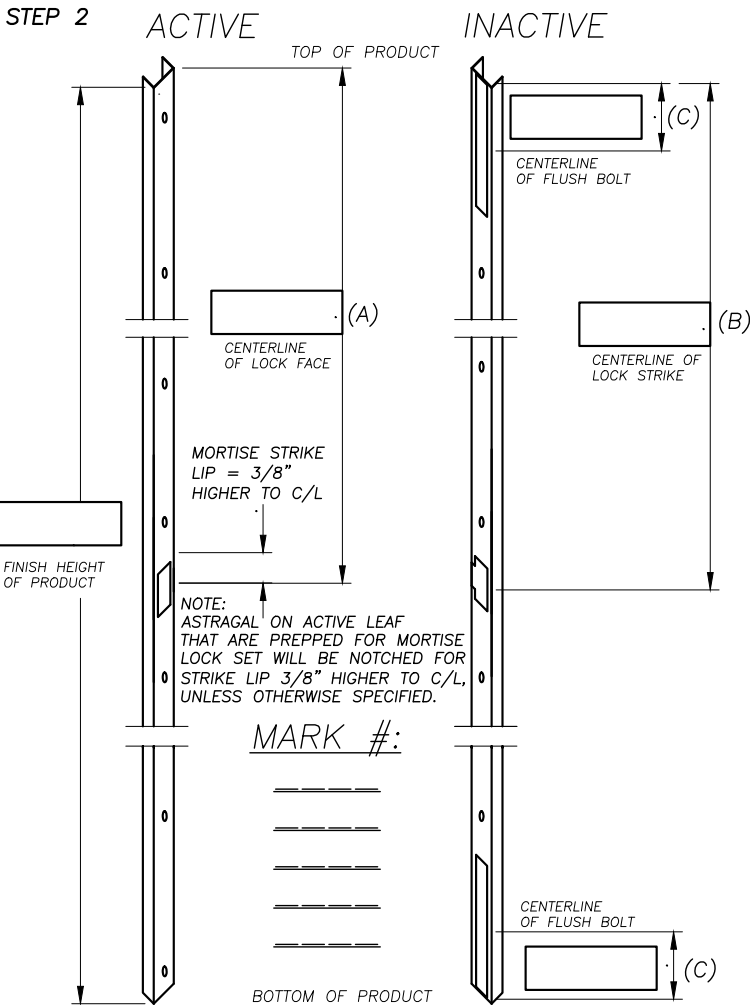

COMPANY:	
PO#:	DATE:
JOB NAME:	
MODEL #:	FINISH:
SIGNATURE:	

NOTE: SOME DEAD BOLT PREPS ARE AVAILABLE. PLEASE CONSULT FACTORY

PLEASE COMPLETE steps 1 thru 3:
 1. Quantity for each hand
 2. Hardware locations
 3. Select hardware preps

REV.DATE: 06/09/2017

FINGER GUARD



Finger Guard is Designed to Help Prevent Injury to Fingers Accidentally Placed in the Hinge Area of a Door. This Unique Product Features an Internal Spring Mechanism That Maintains Constant Tension Against the Polyethylene Fabric Which Helps Prevent Fingers From Entering the Dangerous Area Behind the Edge of the Door.

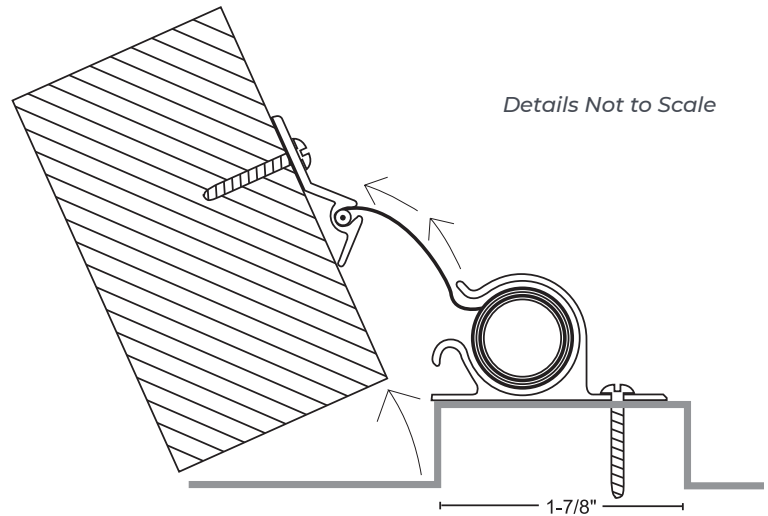

- ▶ Ideal for Senior & Childcare Facilities
- ▶ Anodized Aluminum Housing
- ▶ Durable "Endless Cycle" Spring Mechanism
- ▶ Fire-Resistant Woven Polyethylene Fabric
- ▶ Rated Up To 3 Hours Metal Doors, 1-Hour Wood Doors
- ▶ 82" for 7' Door Opening
- ▶ 38" Dutch Door Size
- ▶ Custom Lengths 12" up to 86" Available. Order 2" Less Than Opening Height to Allow for the Stop on the Door Frame Head and Door Bottom Undercut
- ▶ Not Field Sizable
- ▶ Mounts on Push Side of Door
- ▶ Suitable for Doors Swinging Up To 180 Degrees
- ▶ #6 x 1/2" Tek Self-Drilling Screws Furnished

Door Shown in Open Position



SKU	DESCRIPTION
2248A	Aluminum Clear Anodized with White Polyethylene
2248DKB	Dark Bronze Anodized with Black Polyethylene

Available in 38", 76", 82" and 86" Standard Lengths

HINGE SIDE FINGER GUARD



NGP Order Form (Page EA8) Indicating Model Number, Hand, Net Length, Hardware Preps, and Precise Hardware Locations Must Accompany All Orders.

- ▶ Flexible Vinyl With Rigid Thermoplastic Base
- ▶ Rated Up To 3 Hours Metal Doors, 1½" Hours Wood Doors
- ▶ Available in Brown, Charcoal and White
- ▶ 83" Length
- ▶ Can Be Cut in the Field
- ▶ Mounts on Pull Side of Door
- ▶ #6 X ½" Tek Self-Drilling Screws

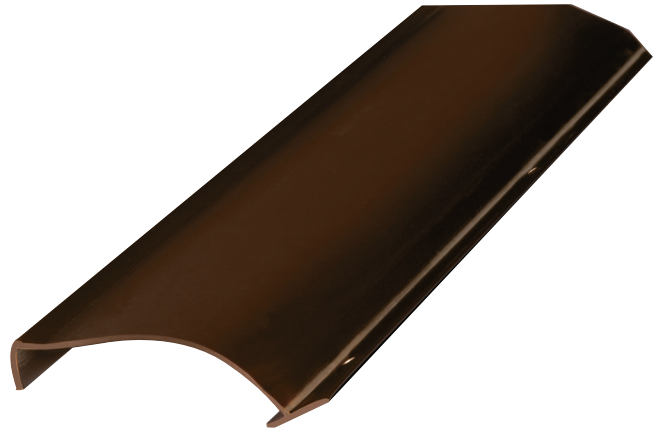

SKU	COLOR
2252A	Brown
2252C	Charcoal
2252W	White

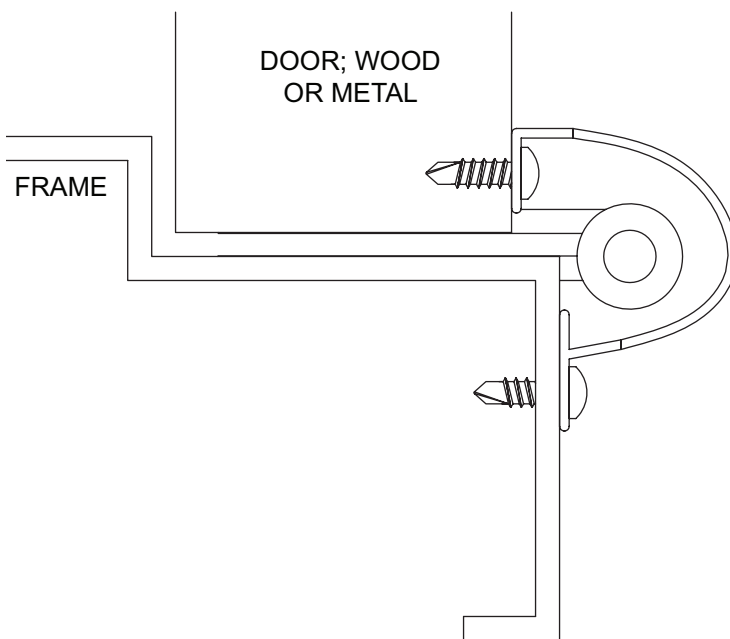

FLOOD SHIELD

DROP IN AND GO!

Flood Shield is Designed to Help Protect Door Openings and Building Contents from Flood Water. This Unique Product Features a Spring Mechanism that Maintains Constant Tension Against the Gasketing to Create a Solid Flood Barrier.

- ▶ Stainless Steel Springs Provide Constant Seal Compression
- ▶ ¼" Marine Grade Aluminum Shield with Handle Cutouts
- ▶ Closed Cell Neoprene Rubber Gaskets Installed on Bottom and Sides of Shield

SKU	HEIGHT	
FS10	12" High	With 10" of Flood Protection
FS22	24" High	With 22" of Flood Protection
FS34	36" High	With 34" of Flood Protection

* Up To 96" Wide

* Over 50" Support Post Recommended

* Complies With Guidelines of the Federal Emergency Management Agency (FEMA) and Federal Insurance and Mitigation Administration (FIMA) for Use on Doors in Flood Prone Areas.



FLOOD SHIELD

- ▶ ¼" Marine Grade Aluminum Shield with Handle Cutouts
- ▶ Closed Cell Neoprene Rubber Gaskets Installed on Bottom and Sides of Shield
- ▶ Anodized Aluminum Mounting Channels
- ▶ Universal Channels can Install Inside or Outside Mount
- ▶ Dark Bronze Mounting Channels Available (Specify)
- ▶ Stainless Steel Springs Provide Seal Compression
- ▶ #10 x 1 ½" Stainless Steel Sheet Metal Screws
- ▶ Complies with Guidelines of the Federal Emergency Management Agency (FEMA) and Federal Insurance and Mitigation Administration (FIMA) for Use on Doors in Flood Prone Areas
- ▶ Lengths Up To 96" Available
- ▶ A Center Support Post is Recommended for Installations Over 50"
- ▶ A Threshold is Recommended if Sill is Not Smooth and Clean
- ▶ Orders for this Product are Non-Changeable and Non-Cancellable

SKU	HEIGHT	
FS10	12" High	With 10" of Flood Protection
FS22	24" High	With 22" of Flood Protection
FS34	36" High	With 34" of Flood Protection

MOUNTING CHANNEL

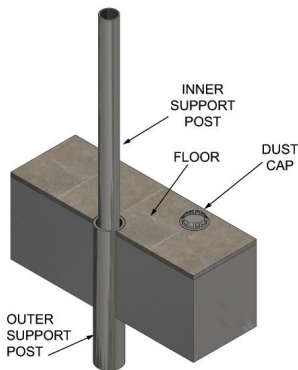
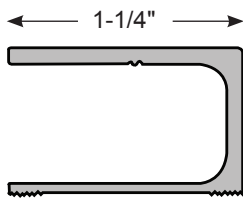

FSSP *Optional Center Support & Cap*

INSIDE MOUNT

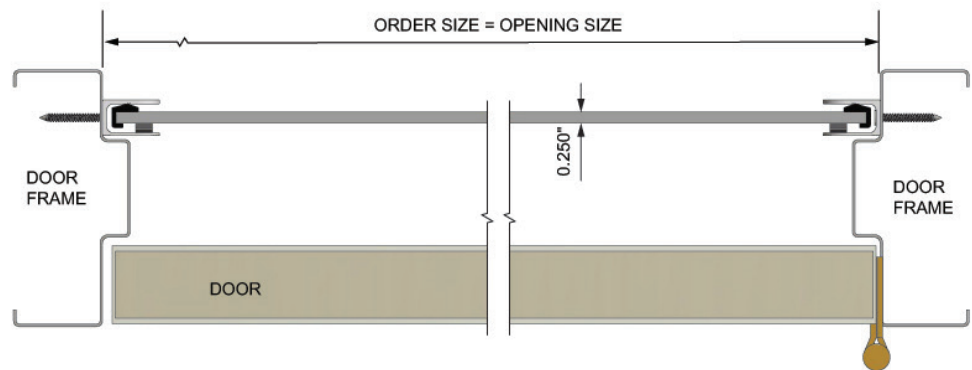

OUTSIDE MOUNT

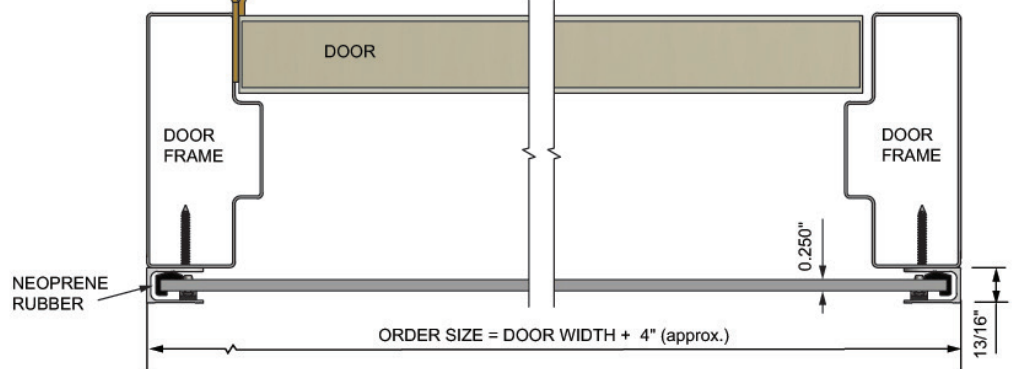

NOTES

NOTES





For the most up-to-date
Seals, Edges, Astragals &
Specialty Products Catalog
scan the QR code or visit
ngp.com.



ngp.com
1-800-NGP-RUSH

FAX: (800) 255-7874
QUOTES: quotes@ngp.com

NGP MEMPHIS

4985 East Raines Road
Memphis, TN 38118
orders@ngp.com

NGP VEGAS

4584 Calimesa Street
Las Vegas, NV 89115
vegasorders@ngp.com