



# GAPGUARD™

— FIRE DOOR ACCESSORIES —





## GAPGUARD™ INDEX:

	<b>Page</b>
Cylindrical Hardware Prep Filler.....	GAP10
DOORGAP GAUGE® .....	GAP14
End Caps .....	GAP13
Fire Door Bottom Gap Solution .....	GAP6-GAP7
Fire Door Head and Jamb Gap Solution.....	GAP2
Fire Door Head and Jamb Gap Solution for Narrow Soffit.....	GAP3
Fire Door Top Gap Solution.....	GAP4
Flush Bolt Hardware Prep Filler.....	GAP8
GAPGUARD™ 90 Minute Strike Shims.....	GAP12
GAPGUARD™ 90 Minute Thru-Bolts.....	GAP12
GAPGUARD™ FIRE CAULK .....	GAP11
GAP90-ME Meeting Edge Gap Solution .....	GAP5
Hardware Prep Fillers.....	GAP11
Mortise Hardware Prep Filler.....	GAP9
Steel Hinge Shims .....	GAP13

## NUMERICAL INDEX:

DOORGAP GAUGE® .....	GAP14	GAP90NDKB™ .....	GAP3	5075.....	GAP3
FDTB .....	GAP12	GAP90NW™ .....	GAP3	9225.....	GAP12
GAPGUARD™		GAP90W™ .....	GAP2	9275.....	GAP12
FIRE CAULK .....	GAP11	HP90 .....	GAP11	9590 .....	GAP6
GAP90™ .....	GAP2	HP90-CYL .....	GAP10	9595.....	GAP7
GAP90DKB™ .....	GAP2	HP90-FB .....	GAP8	9990.....	GAP4
GAP90-ME.....	GAP5	HP90-MORT.....	GAP9	9945EC.....	GAP13
GAP90N™ .....	GAP3	HS-1.....	GAP13	9945NEC.....	GAP13

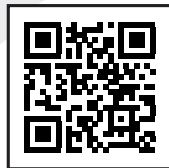

For the complete list of GapGuard™ Fire Door Accessories, the most up-to-date product information and installation instructions, scan the QR code or **visit [ngp.com](http://ngp.com)**.

# RATINGS AND LEED

## RATING SYMBOLS LEGEND

---



**POSITIVE PRESSURE - CERTIFIED by UL to ANSI/UL10C;** complies with IBC, NFPA 80 and NFPA 252 for application to Hollow Metal fire doors rated up to 3 hrs., and Wood fire doors rated up to 90 minutes (some ratings vary as noted).



**CERTIFIED by UL to CAN/ULC-S104 and ANSI/UL10B,** complies with NFPA 80 and NFPA 252 for application to Hollow Metal fire doors rated up to 3 Hrs., and Wood fire doors rated up to 90 minutes (some ratings vary as noted).



**SMOKE & DRAFT CONTROL GASKETING,** Certified by UL to ANSI/UL10C and ANSI/UL1784 Category 'H'; complies with IBC and NFPA 105 for use on 'S' labeled Positive Pressure Hollow Metal fire doors rated up to 3 hours, and Wood fire doors rated up to 90 minutes (some ratings vary as noted).



**ACOUSTICAL TESTED** to ASTM E90 Standard Test Method for Laboratory Measurement of Airborne Sound Transmission Loss of Building Partitions and Elements, and ASTM E2235 Standard Test Method for Determination of Decay Rates for use in Sound Insulation Test Methods. Refer to information on pages G4 and G5 of our full catalog for test result data.



**AIR INFILTRATION TESTED** to ASTM E283, Standard Test Method for Determining Rate of Air Leakage Through Exterior Windows, Curtain Walls, and Doors.



**ANTI-MICROBIAL** Treated with an anti-microbial additive to prohibit the growth of microorganisms.



**ANSI/BHMA CERTIFIED** Certified gasketing complies with American National Standard for Door Gasketing and Edge Seal Systems ANSI/BHMA A156.22, and is listed in the BHMA Certified Products Directory.



Online product listings: [www.ul.com/database](http://www.ul.com/database)



## LEED GREEN BUILDING

The LEED (Leadership in Energy and Environmental Design) Green Building Rating System® is a national standard for developing high-performance, sustainable buildings developed by the U. S. Green Building Council.

Our current LEED letter containing LEED qualification information for all our products is available at [www.ngp.com](http://www.ngp.com)

Environmental Product Declarations (EPD) prepared and certified by an Independent Laboratory based on Life Cycle Assessments (LCA) of our products may be viewed on our website, [www.ngp.com](http://www.ngp.com)

Health Product Declarations (HPD) may be viewed on our website, [www.ngp.com](http://www.ngp.com)

National Guard Products sustainability report may be viewed on our website, <https://www.ngp.com/report/>

Contact us regarding our end of use product recycling program.

# GAP90™

## FIRE DOOR HEAD AND JAMB GAP SOLUTION



UL Certified Solution for Fire Doors with Excessive Clearance Between Door and Frame Over  $\frac{1}{8}$ " , up to  $\frac{5}{16}$ " .

INSTALLED  
VIEW

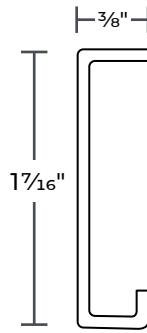
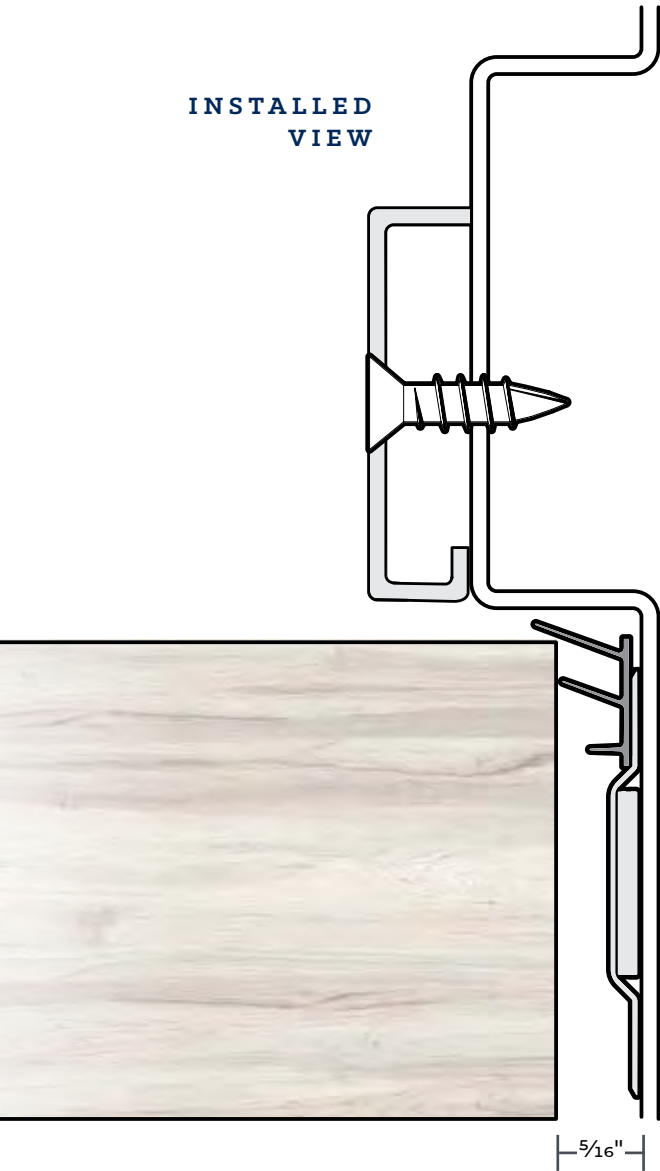

### PRODUCT CONSISTS OF:

#### 9945

Steel Stop Extender

- ◆ 16-Gauge, Gray Primer Finish
- ◆ Furnished with #10 X 1" TEK SMS
- ◆ Patent No.: US9,273,510B2
- ◆ Embossed with **UL Mark**

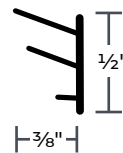

#### 5075

Self-Adhesive TPE Seal

5075B BROWN

5075CL CLEAR\*

5075W WHITE

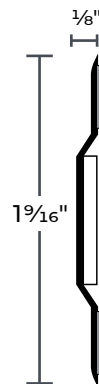

#### 9400

NGP-Edge® Intumescent Seal with PVC Cover

9400 GRAY

9400DKB BROWN

9400W WHITE

90-Minute rated UL Certified Miscellaneous Fire Door Accessory on UL10B and UL10C wood or hollow metal fire doors.

An NGP Strike Shim 9275 or 9225 may also be required for proper latchbolt engagement.

Doors with parallel arm closers — use 9990 Fire Door Top Gap Solution.

GAP90™ INCLUDES 9945, 9400, 5075CL

GAP90DKB™ INCLUDES 9945, 9400DKB, 5075B

GAP90W™ INCLUDES 9945, 9400W, 5075W

Available in 36", 48", 84" and 96" Lengths

# GAP90N™

FIRE DOOR HEAD AND JAMB GAP SOLUTION FOR NARROW SOFFIT



UL Certified Solution for Fire Doors with Excessive Clearance Between Door and Frame Over  $\frac{1}{8}$ " , up to  $\frac{5}{16}$ " and a Soffit Measuring  $\frac{1}{2}$ " to  $1\frac{1}{2}$ ".

## PRODUCT CONSISTS OF:

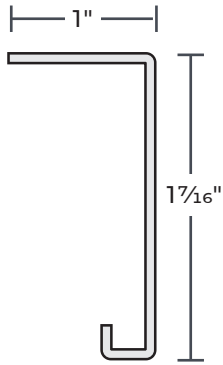

### 9945N

Steel Stop Extender

- ▶ 16-Gauge, Gray Primer Finish
- ▶ Furnished with #10 X 1" TEK SMS
- ▶ Patent No.: US9,273,510B2
- ▶ Embossed with **UL Mark**

### 5075

Self-Adhesive TPE Seal

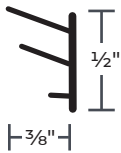

5075B BROWN

5075CL CLEAR\*

5075W WHITE



### 9400

NGP-Edge® Intumescent Seal with PVC Cover

9400 GRAY

9400DKB BROWN

9400W WHITE

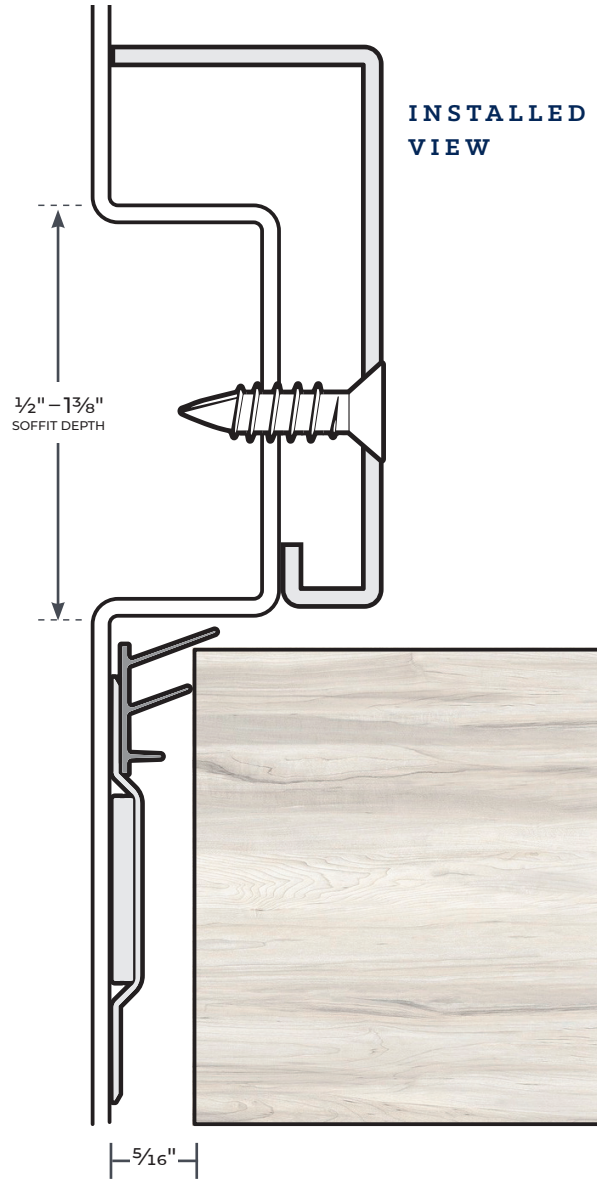

90-Minute rated UL Certified Miscellaneous Fire Door Accessory on UL10B and UL10C wood or hollow metal fire doors.

An NGP Strike Shim 9275 or 9225 may also be required for proper latchbolt engagement.

Doors with parallel arm closers — use 9990 Fire Door Top Gap Solution.

GAP90N™ INCLUDES 9945N, 9400, 5075CL

GAP90NDKB™ INCLUDES 9945N, 9400DKB, 5075B

GAP90NW™ INCLUDES 9945N, 9400W, 5075W

Available in 36", 48", 84" and 96" Lengths

# 9990

## FIRE DOOR TOP GAP SOLUTION

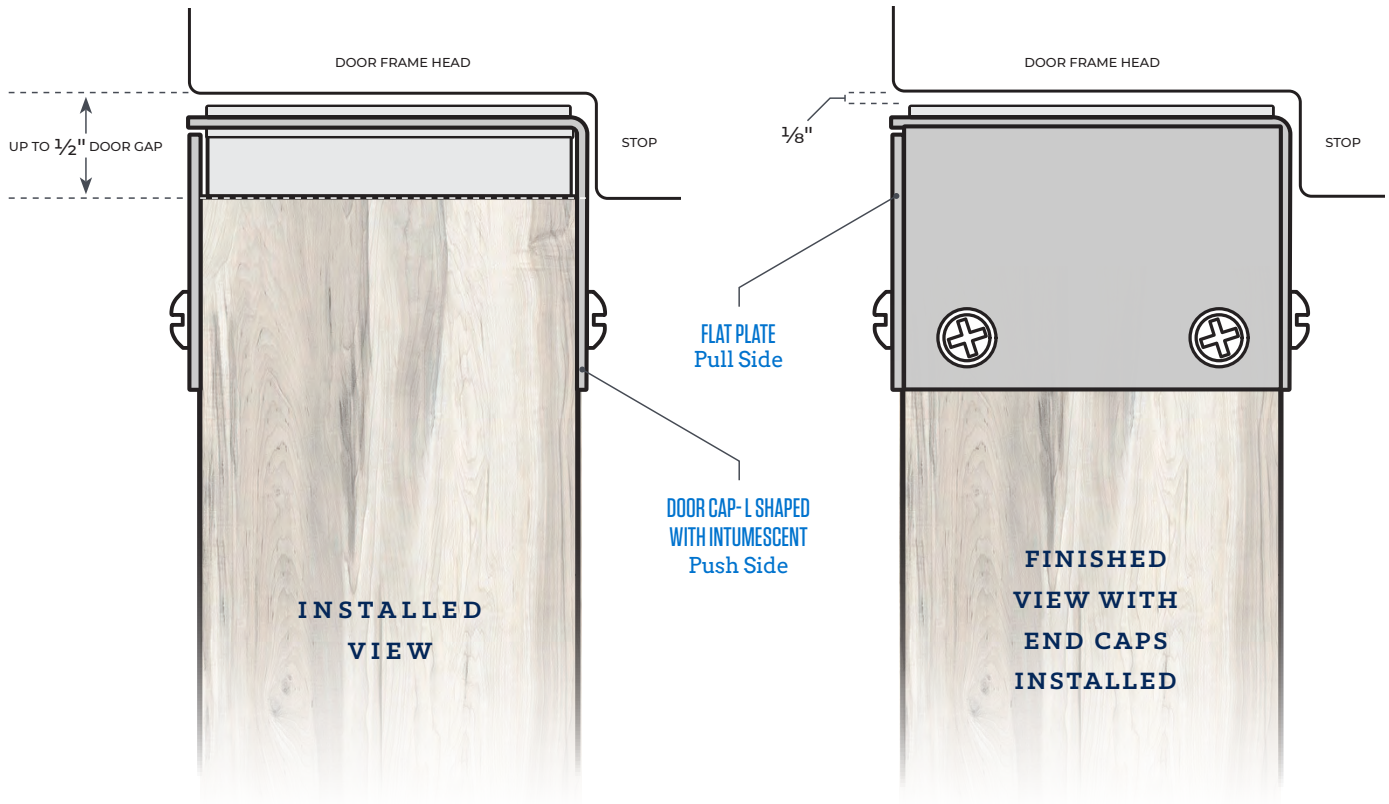

## PRODUCT INFORMATION

### UL Certified for Door Top Gaps — Measuring up to 1/2".

- ▶ 90-Minute Rated — for use on UL10B and UL10C wood or hollow metal fire doors
- ▶ Recommended for doors with parallel arm closers
- ▶ Patent Pending
- ▶ Available in 36" and 48" lengths
- ▶ Brushed stainless steel
- ▶ Non-handed

### PRODUCT CONSISTS OF:

- + #304 Brushed Stainless Steel Flat Plate - Pull Side
- + #304 Brushed Stainless Steel Intumescent Cap—Push Side
- + #304 Brushed Stainless Steel End Caps
- + #6 x 3/4" Stainless Steel SMS Furnished

# GAP90-ME

## MEETING EDGE GAP SOLUTION



**UL Certified Solution for Fire Doors with Excessive Clearance Between the Meeting Edges of a Pair of Doors, up to  $\frac{3}{8}$ ".**

- ▶ Application Certified on both Hollow Metal and Wood Fire-Rated Doors, up to 90-Minute
- ▶ Patent Pending
- ▶ Non-Handed
- ▶ Certified for use on Doors with Surface/ Concealed Vertical Rod Exit Devices or Manual/Automatic Flush Bolts (see *Installation Instructions*)
- ▶ Can be Installed with the Door on the Hinges
- ▶ Can be Field-Modified to Match-Fit Varying Width Gap Along Height of the Door (see *installation instructions*)

### PRODUCT CONSISTS OF:

- + Formed Metal Edge, 20-Gauge Steel, Embossed With UL Mark
- + Powder Coated, Primer Gray
- + Hardware Pack
  - #10 x  $\frac{3}{4}$ " FHPH SS TEK
  - #10 x  $2\frac{1}{2}$ " FHPH SS SMS
- + GapGuard™ Fire Caulk (see *Installation Instructions*)



### SPECIAL NOTES:

• 90-minute rated UL Certified Miscellaneous Fire Door Accessory on UL10B and UL10C wood or hollow metal fire doors

- An NGP Strike Shim 9275 or 9225 may also be required for proper latchbolt engagement
- Certified for on-site modifications around strike location
- If fire pins are used, it is recommended to apply metal edge to door with fire pin receiver, ensuring receiver is flush with metal edge
- To retain UL Certification, the Gap90-ME must be installed using GapGuard™ Fire Caulk

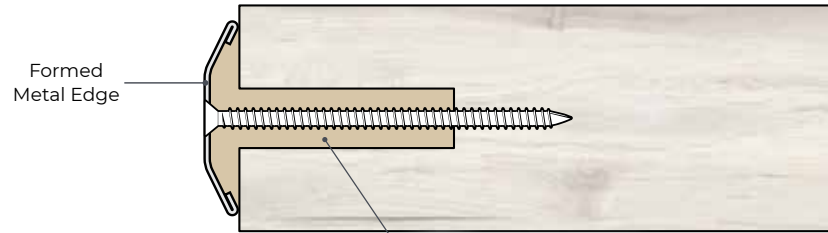

1/2" x 1 1/2" Cylindrical Anchoring Bore Filled With Gapguard™ Fire Caulk (wood door application only)

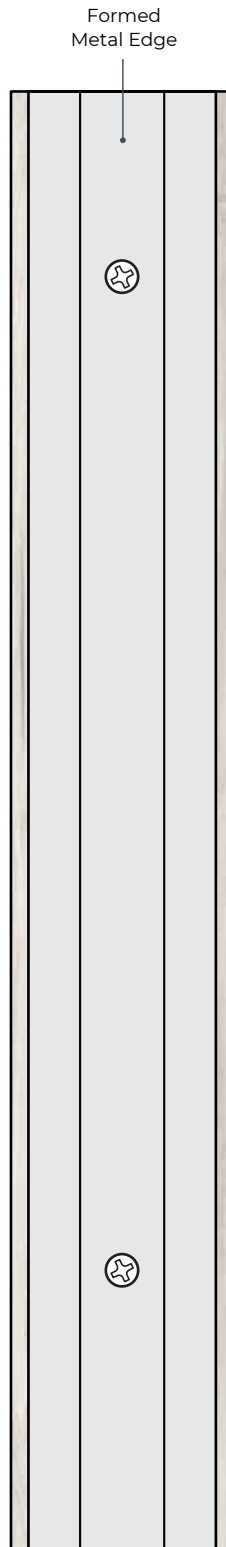

1/2" x 1 1/2" Cylindrical Anchoring Bore Filled With Gapguard™ Fire Caulk (wood door application only)

1/2" x 1 1/2" Cylindrical Anchoring Bore Filled With Gapguard™ Fire Caulk (wood door application only)

**WOOD DOOR  
INSTALLATION SHOWN**

# 9590

## DOOR BOTTOM GAP SOLUTION

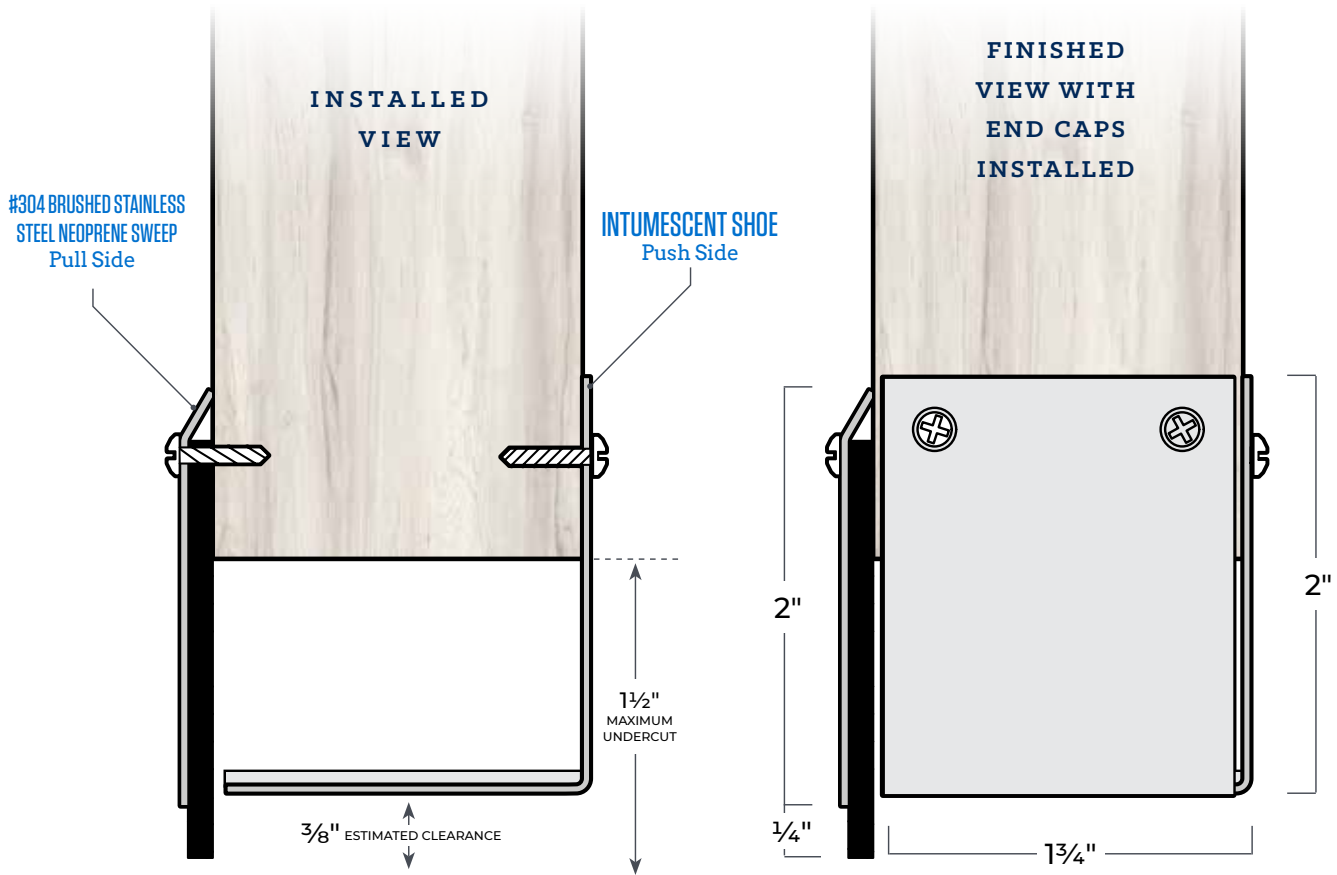

## PRODUCT INFORMATION

### UL Certified for Door Bottom Gaps — Measuring up to 1 1/2".

- Restricts the passage of smoke
- 90-Minute Rated — for use on UL10B and UL10C wood or hollow metal fire doors
- Patent Pending
- Available in 36" and 48" Lengths
- Non-Handed

### PRODUCT CONSISTS OF:

- + #304 Brushed Stainless Steel Neoprene Sweep — Pull Side
  - + #304 Brushed Stainless Steel Intumescent Shoe — Push Side
  - + #304 Brushed Stainless Steel End Caps
  - + #6 × 3/4" Stainless Steel SMS Furnished
- Brushed stainless steel  
Neoprene is black*



# 9595DKB

DOOR BOTTOM GAP SOLUTION

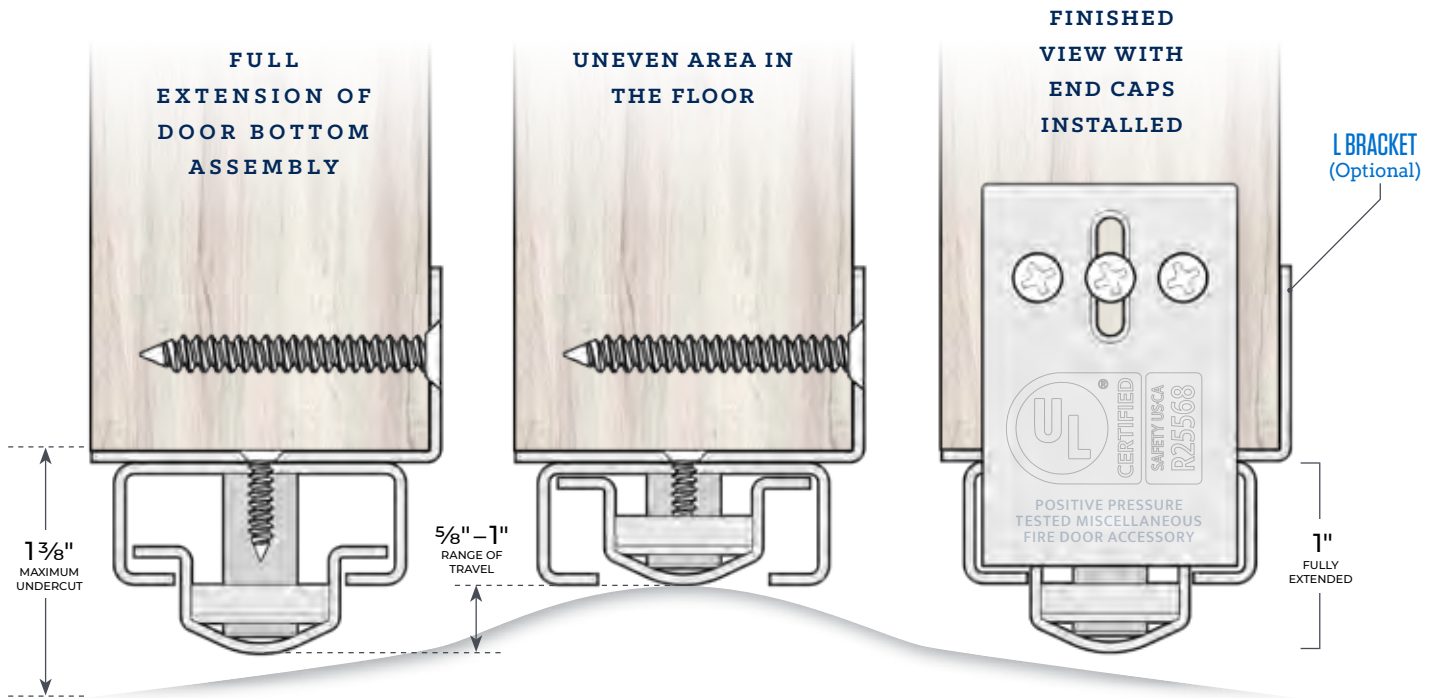

## PRODUCT INFORMATION

**UL Certified Solution for Fire Doors With Excessive Clearance Between the Bottom of the Door and Finished Floor, up to 1 3/8".**

- ▶ Application Certified on both Hollow Metal and Wood Fire-Rated Doors, up to 90-Minutes
- ▶ Patent Pending
- ▶ Non-Handed
- ▶ L-bracket allows Installation while Door Remains on Hinges
- ▶ Field Trim to Fit: up to 1 1/2" per side, 3" total
- ▶ Designed to Travel Over Uneven Floors, with a range of 3/8"
- ▶ May be Fastened to the Underside of the Door's Bottom Rail to Minimize Visibility.
- ▶ End Caps Set Height Position and Provide a Finished Look
- ▶ Sizes: 36", 42" and 48"

## PRODUCT CONSISTS OF:

- + L-Bracket, 16-Gauge Steel, Embossed with UL Mark
- + Door Bottom Assembly, 18-Gauge Steel
- + End Caps, 18-Gauge Steel, Embossed With UL Mark
- + Hardware Pack
  - #10 x 1 1/2" PHPH SS SMS (DKB)
  - #8-32 x 1 3/4" PHP SS Thru-Bolt (DKB)
  - #6 x 3/8" SS TEK
  - #10 x 2" PHPH SS SMS
  - #6 x 3/4" FPHP SS SMS (DKB)

*Powder Coated, DKB*

# HP90-FB

FLUSH BOLT HARDWARE PREP FILLER



**UL Certified Solution for Fire Doors When Either Removing Existing Hardware and/or Using a New Hardware Type Over Existing Hardware Prep's.**

## PRODUCT INFORMATION

- ▶ Application Certified On Both Hollow Metal And Wood Fire Rated Doors Up To 90-Minutes
- ▶ Patent Pending
- ▶ Certified for Filling Manual or Automatic Flush Bolt Cavities

### PRODUCT CONSISTS OF:

- + HP90 – 2" x 6" Rectangular Fire-Rated Panel
- + HP90 – 0.5 Cylindrical Fire-Rated Panel
- + Steel Filler Plates: (*Powder Coated Primer Gray, Embossed With UL Mark*)
  - HP90-FBE6750, Edge Filler Plate
  - HP90-FBE8500, Edge Filler Plate
  - HP90-FBL2000, Latch Bolt Filler Plate
  - HP90-FBL2500, Latch Bolt Filler Plate
  - HP90-FBL3875, Latch Bolt Filler Plate
  - HP90-SF2250, Strike Filler Plate
- + Hardware Pack
  - #10-32 x 1-3/4" FHPH SS machine screw
  - #8 x 3/4" FHPH SS combo screw
  - #12 x 1" FHPH SS combo screw
  - #8 x 3/4" FHPH SS SMS
  - #12 x 1" FHPH SS SMS
- + GapGuard™ Fire Caulk (*see Installation Instructions*)

**WOOD DOOR  
INSTALLATION  
SHOWN**



### SPECIAL NOTES:

- 90-minute rated UL Certified Miscellaneous Fire Door Accessory on UL10B and UL10C wood or hollow metal fire doors
- To retain UL Certification, the HP90-MORT must be installed using GapGuard™ Fire Caulk

# HP90-MORT

MORTISE HARDWARE PREP FILLER



**UL Certified Solution for Fire Doors When Either Removing Existing Hardware and/or Using a New Hardware Type Over Existing Hardware Prep's.**

## PRODUCT INFORMATION

- ▶ Application Certified on Both Hollow Metal and Wood Fire-Rated Doors – up to 90-Minute
- ▶ Patent Pending
- ▶ Certified for Filling Mortise Lockset Cavities

### PRODUCT CONSISTS OF:

- + HP90 – 4" x 6" Fire-Rated Panel
- + Steel Filler Plates: *(Powder Coated Primer Gray, Embossed With UL Mark)*
  - HP90-MEF1258, Edge Filler Plate
  - HP90-SF4875, Strike Filler Plate
- + Hardware Pack
  - #10-32 x 1-3/4" FHPH SS machine screw
  - #8 x 3/4" FHPH SS combo screw
  - #12 x 1" FHPH SS combo screw
  - #8 x 3/4" FHPH SS SMS
  - #12 x 1" FHPH SS SMS
- + GapGuard™ Fire Caulk *(see Installation Instructions)*



#### SPECIAL NOTES:

- 90-minute rated UL Certified Miscellaneous Fire Door Accessory on UL10B and UL10C wood or hollow metal fire doors

· To retain UL Certification, the HP90-MORT must be installed using GapGuard™ Fire Caulk

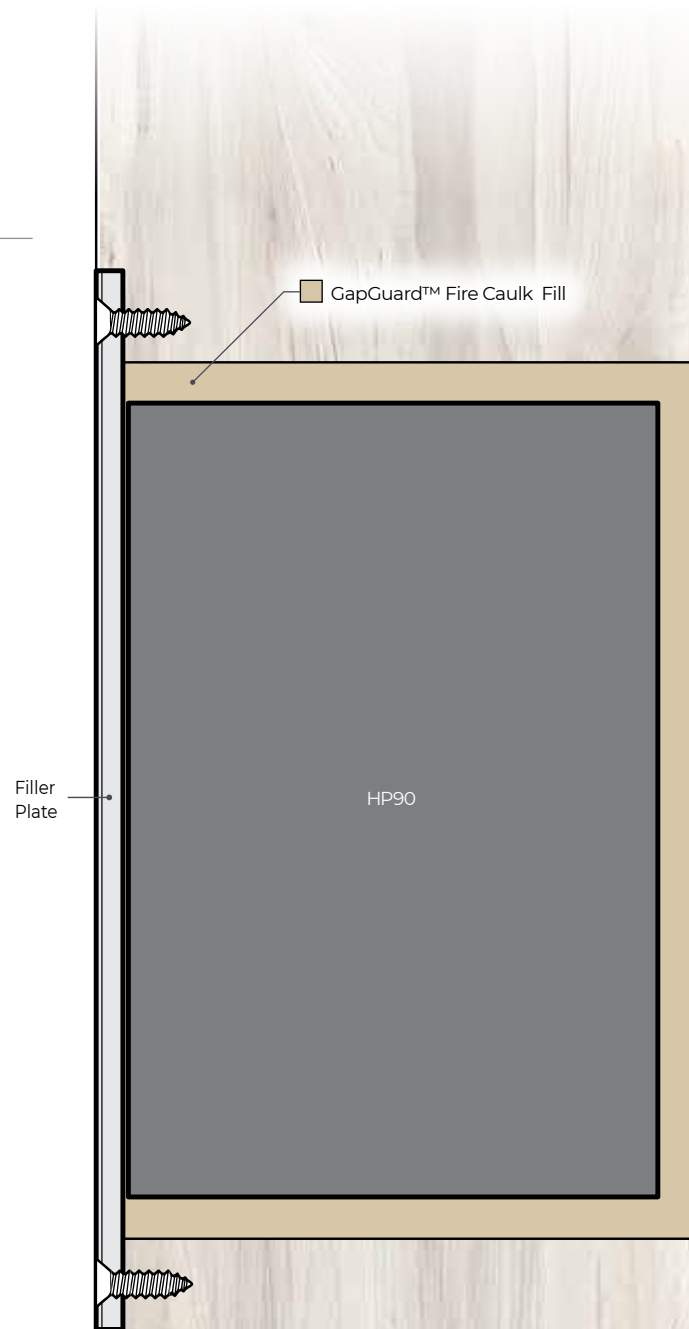

**WOOD DOOR  
INSTALLATION  
SHOWN**

# HP90-CYL

## CYLINDRICAL HARDWARE PREP FILLER



**UL Certified Solution for Fire Doors When Either Removing Existing Hardware and/or Using a New Hardware Type Over Existing Hardware Prep's.**

- ▶ Application Certified on both Hollow Metal and Wood Fire Rated Doors, up to 90 Minutes
- ▶ Patent Pending
- ▶ Certified for Filling Cylindrical Lockset Cavities

### PRODUCT CONSISTS OF:

- + Fire-Rated Panels:
  - HP90 – 2.0
  - HP90 – 1.0
  - HP90 – 0.5
- + Steel Filler Plates, powder coated, primer gray, embossed with UL Mark
  - HP90-RDCP, Filler Plate
  - HP90-CEF1000, Edge Filler Plate
  - HP90-SF2750, Strike Filler Plate
  - HP90-SF4875, Strike Filler Plate
- + Hardware Pack
  - #10-32 x 1 3/4" FHPH SS machine screw
  - #8 x 3/4" FHPH SS combo screw
  - #12 x 1" FHPH SS combo screw
  - #8 x 3/4" FHPH SS SMS
  - #12 x 1" FHPH SS SMS
- + GapGuard™ Fire Caulk  
*(see Installation Instructions)*

### WOOD DOOR: INSTALLED VIEW



■ GapGuard™ Fire Caulk Fill

### STEEL DOOR: INSTALLED VIEW



■ GapGuard™ Fire Caulk Fill



### SPECIAL NOTES:

- 90-minute rated UL Certified Miscellaneous Fire Door Accessory on UL10B and UL10C wood or hollow metal fire doors
- To retain UL Certification, the HP90-MORT must be installed using GapGuard™ Fire Caulk

# HP90

## HARDWARE PREP FILLERS



UL Certified Solution for Fire Doors When Either Removing Existing Hardware and/or Using a New Hardware Type Over Existing Hardware Prep's.



- ▶ Application Certified on both Hollow Metal and Wood Fire Rated Doors, up to 90 Minutes
- ▶ Certified for Use in Combination With Gap Guard™ Fire Caulk to Fill Thru-Holes Between ½" Diameter and 2 ½" Diameter

PART NO.	DESCRIPTION
HP90 - 0.5	½" diameter hardware prep filler (10 Pack)
HP90 - 1.0	1" diameter hardware prep filler (10 Pack)
HP90 - 1.5	1½" diameter hardware prep filler (10 Pack)
HP90 - 2.0	2" diameter hardware prep filler (10 Pack)

# GAPGUARD™ FIRE CAULK



UL Certified Solution for Fire Doors and Frames to Seal Thru-Holes as well as in Combination With Other Hardware Prep Filler Solutions.

## PRODUCT INFORMATION

- ▶ Application Certified on both Hollow Metal and Wood Fire-Rated Doors, up to 90-Minutes
- ▶ Can be used to fill up to a ½" Diameter Thru-Hole
- ▶ Fully Cured in 24 Hours
- ▶ Can be Sanded and Painted after Full Cure
- ▶ Indoor Use Only
- ▶ Shelf Life is 12 Months
- ▶ 10.3 fl. oz. Cartridge
- ▶ 10 Tubes per Box

Color: Tan



# GAPGUARD™ STRIKES

90 MINUTE STRIKE SHIMS



UL Certified Miscellaneous GAPGUARD™ for Excessive Door and Frame Clearances, Measuring up to 5/16".

**9275** - Fits 4 7/8" 'ASA' Strike Plate

**9225** - Fits 2 3/4" 'T' Strike Plate

UL Certified Miscellaneous Fire Door Accessory for Excessive Door and Frame Clearances, Measuring Up To 5/16"

Required for Proper Latchbolt Engagement  
90-Minute Rated UL10B and UL10C Wood or Hollow Metal Fire Doors

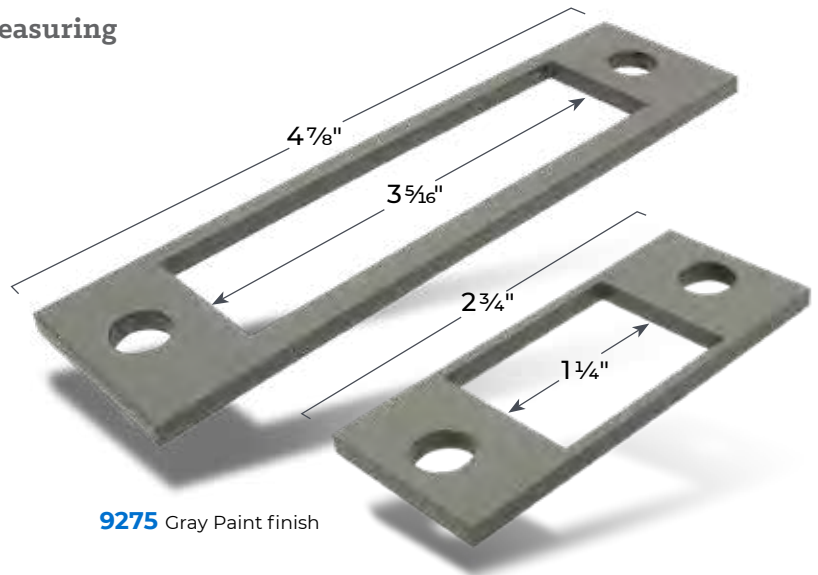

**9275** Gray Paint finish

**9225** Gray, Paint finish

# GAPGUARD™ THRU-BOLTS

90 MINUTE THRU-BOLTS



- ▶ Fits 1 3/4" to 2" Thick Doors
- ▶ Zinc-Plated Steel Sleeve with Machine Screws
- ▶ Meets Requirements of NFPA 80 for Use on Fire Doors
- ▶ Use to Fill Holes in Wood or Steel Fire Doors to Protect Label Compliance
- ▶ Available in Boxes of Twenty

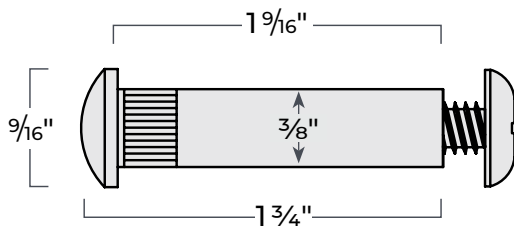

**FDTB 3/8"**

Thread Size 3/4-20

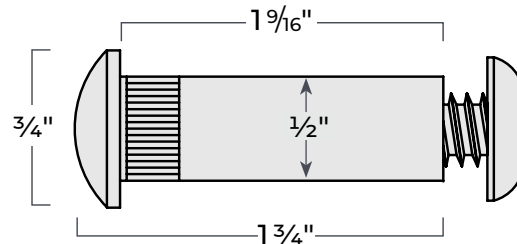

**FDTB 1/2"**

Thread Size 9/16-18

# STEEL HINGE SHIMS



## HS-1

- ▶ Use to Shim Hinges to Achieve Required Clearances Between Door and Frame
- ▶ Dual Purpose Shim
  - Use Full 42" Length for Continuous Hinges
  - Break-Off 3 1/2" Sections for Butt Hinges
- ▶ Steel Fire-Rated Shims
- ▶ Pressure Sensitive Adhesive Pads Included for Holding in Place During Installation
- ▶ Removable, Re-Stickable, and Stackable
- ▶ Available in Boxes of Ten

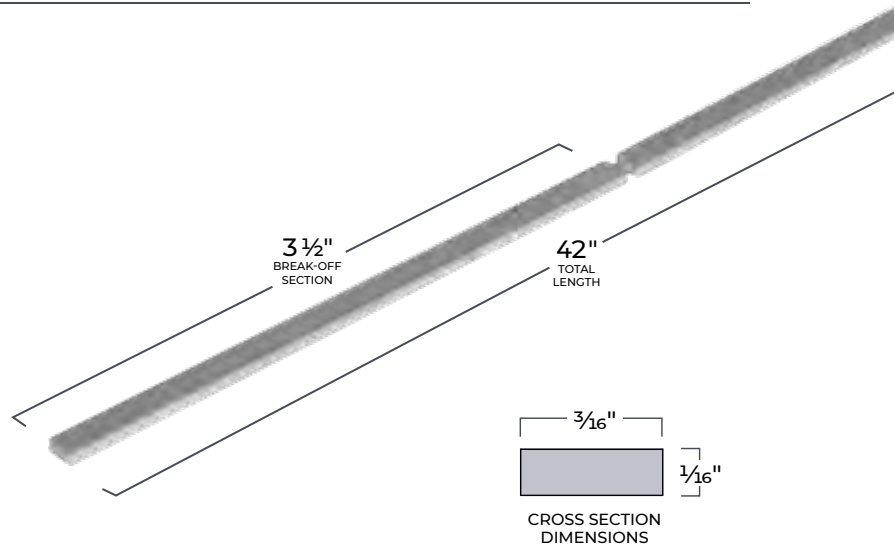

UL Certified Miscellaneous Fire Door Accessory

# 9945EC & 9945NEC

## END CAPS



For Use on GAP90 and GAP90N Steel Stop Extender Components 9945 and 9945N.

- ▶ Use to Cap the Exposed Open End of the Steel Stop Extender When Cut at Rim Panic Strike or Other Hardware
- ▶ Sold in 10 packs

*Sold flat, tabs must be formed prior to use.*

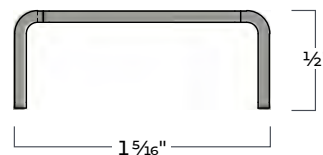

9945EC

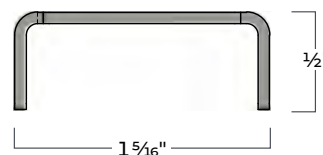

9945NEC



# DOORGAP GAUGE®

## ***The Only Gauge You Will Need to Check Fire Door Assembly Clearance Requirements***

Patented Tool Easily Measures Gap for Fire Door Inspections.

### **Installers**

- ▶ A Sure Way to Check Fire Door Clearance Requirements Before Inspection

### **Inspectors**

- ▶ Will Speed Up Your Inspections
- ▶ More Accurate Than a Tape Measure
- ▶ Compact and Easy to Use

### **Distributors**

- ▶ Supply With Job to Ensure Fire Assemblies Are Installed Per Fire Door Requirements

### ***The Doorgap Gauge® Can Also Be Used To:***

Check Life Safety Egress Assemblies

Check Other Construction Assemblies Requiring Specific Clearances and Operational Tolerances.

## **Common Questions**

### ***Gaps - Perimeter vs. Door Bottom?***

Perimeter gaps in doors are the distance between the edge of the door and door frame as measured on the pull side of the opening. Door bottom gaps are the distance between the bottom of the door and the finish floor.

### ***Gaps - Why Are They Important?***

Proper gap tolerances ensure that the door will perform as it is intended. Gaps that are outside of tolerance can lead to compromised fire door integrity in a fire situation as well as not allowing

the fire door latching mechanism to engage fully as it is required to do by code.

### ***Gaps - What Does the Code Say?***

NFPA 80 (the code standard for fire doors) states that fire doors must be inspected on an annual basis. Maximum allowable perimeter gap is 1/8" for wood doors, 1/8" +/- 1/16" for metal doors. Maximum allowable door bottom gap is 3/4". Gaps that exceed these maximum allowable tolerances result in a non-compliant fire door that needs to be repaired.



## **GAP GAUGE**

(US Patent #7591073)